



Bachmann Industries, Inc.
1400 East Erie Avenue, Philadelphia, PA 19124 USA
www.bachmanntrains.com
Customer Service Telephone 800-356-3910

FB-1 DUMMY DIESEL LOCOMOTIVE INSTRUCTIONS

Thank you for purchasing a Williams by Bachmann® locomotive. This locomotive has been manufactured to provide years of use and enjoyment. Please follow the simple instructions below.

Before operating, please lightly lubricate the points shown in the diagram below. Do not over-lubricate and take extra care to avoid getting lubricants on the wheel surfaces.

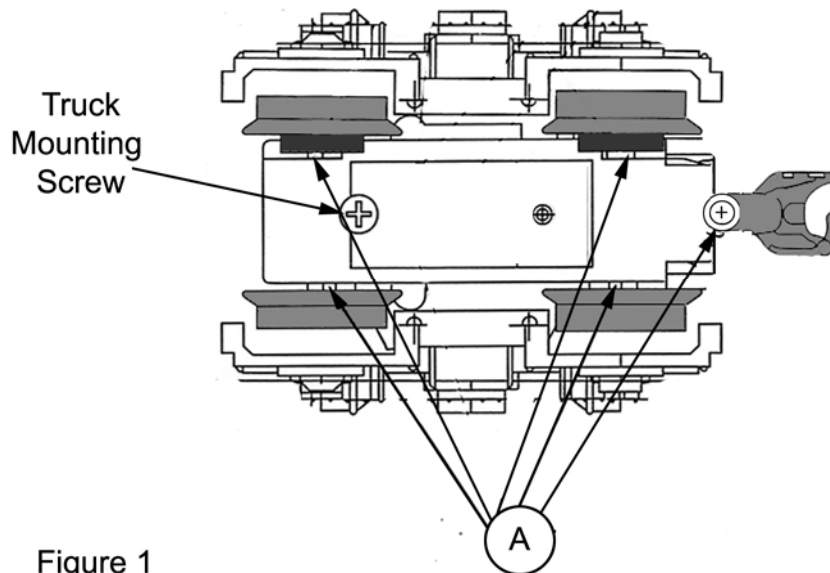

Figure 1

1. For the axles and coupler pivot points **Marked A**, we recommend that you lubricate with a small amount of light oil such as Bachmann E-Z Lube® #99984 Light Gear Oil. **Do not over-lubricate.**

OPERATION

Uncoupling

This dummy locomotive is equipped with fixed couplers, to allow close coupling between the two matching A units. If you run this as the last unit in a lash-up, you will need to use the operating coupler on the first piece of rolling stock in your consist. To uncouple, position the uncoupling plunger of the rolling stock over the center of electro-magnetic track uncoupling section and activate the magnet.

PERIODIC MAINTENANCE

Disassembly Instructions

You will have to remove the body shell to install a power upgrade kit. The body shell is attached with four screws on the bottom of the locomotive frame. The screws are located in each corner of the frame. When you re-attach body shell, please be careful not to over-tighten the screws.

Lubrication

We recommend that you lubricate as directed on page 1 every 10 hours of operation.

Power Upgrade Kit

A power upgrade kit, Williams by Bachmann® #00241, is available to convert this dummy unit into a powered unit. Please follow the installation instructions that are included with the kit.



by BACHMANN

Bachmann Industries, Inc.

1400 East Erie Ave, Philadelphia, PA 19124 USA

www.bachmanntrains.com

Customer Service Telephone 800-356-3910

Part Number	Description	Number Used
ALCO FB-1 DUMMY UNIT BODY & BODY PARTS		
885-E002	Body Shell - complete	1
293-04-01	Ornamental Horn	1
<i>1-35080DPT</i>	<i>Screw(Mounts Body to Frame)</i>	4
885-M011R1E	Metal Frame	1
343-02-01	Fuel Tank	1
<i>1-H30050DBS</i>	<i>Screw(Mounts Fuel Tank & rear ladder to Frame)</i>	8
TRUCK PARTS		
293-M023FR1	Flanged Wheel	8
293-M029NR5	Axle	4
1-30140DPM	Truck Mounting Screw	2
293-07-01B	Non-Operating Coupler	2
<i>885-M013R1</i>	<i>Spring for non-operating coupler</i>	2
1-26060DPWM	Mounting Screw for non-operating coupler	2
1-26220DPM	Long Bolster Screw	2
1-2.6DNUT	Bolster Nut	2
343-05-01	Sideframe	4
1-30060DPM	Sideframe / Bolster Mounting Screw	10
293-M021B	Ladder	2
293-10-03BR1	Truck Mount	2
293-M013R1B	Truck Bolster	2

See Diagram on opposite side for identification. Parts shown in Italics are not illustrated.

ALCO FB-1 (Dummy) Part Identification Chart

